

NON IN DOTAZIONE
BATTERIE ALCALINE (4x1,5V AA)

00	---						
rev.							

ALIMENTATORE
 cod. 00407000014

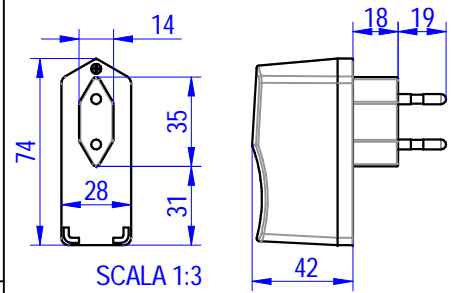

SCATOLA PORTA PILE

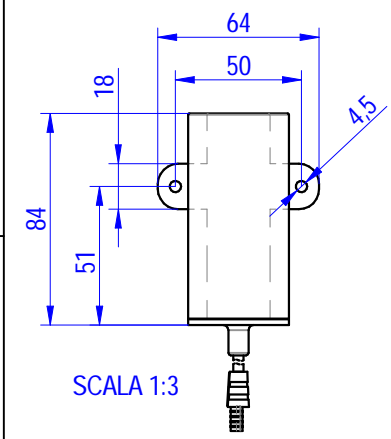

CONNETTORE JOINTER
 cod. 00407000022

ALIMENTATORE
 cod. 00407000014

KIT FISSAGGIO
 cod. 00306000089

FLEX INOX (maschio corto) 6 L/min
 M10x1 - G1/2" L=400mm
 cod. 00403000108

TERMINAZIONE : Alimentatore switching con spina integrata, connettore RJ-9
 ALIMENTAZIONE : 100-240V, 50-60Hz, 0.1 A

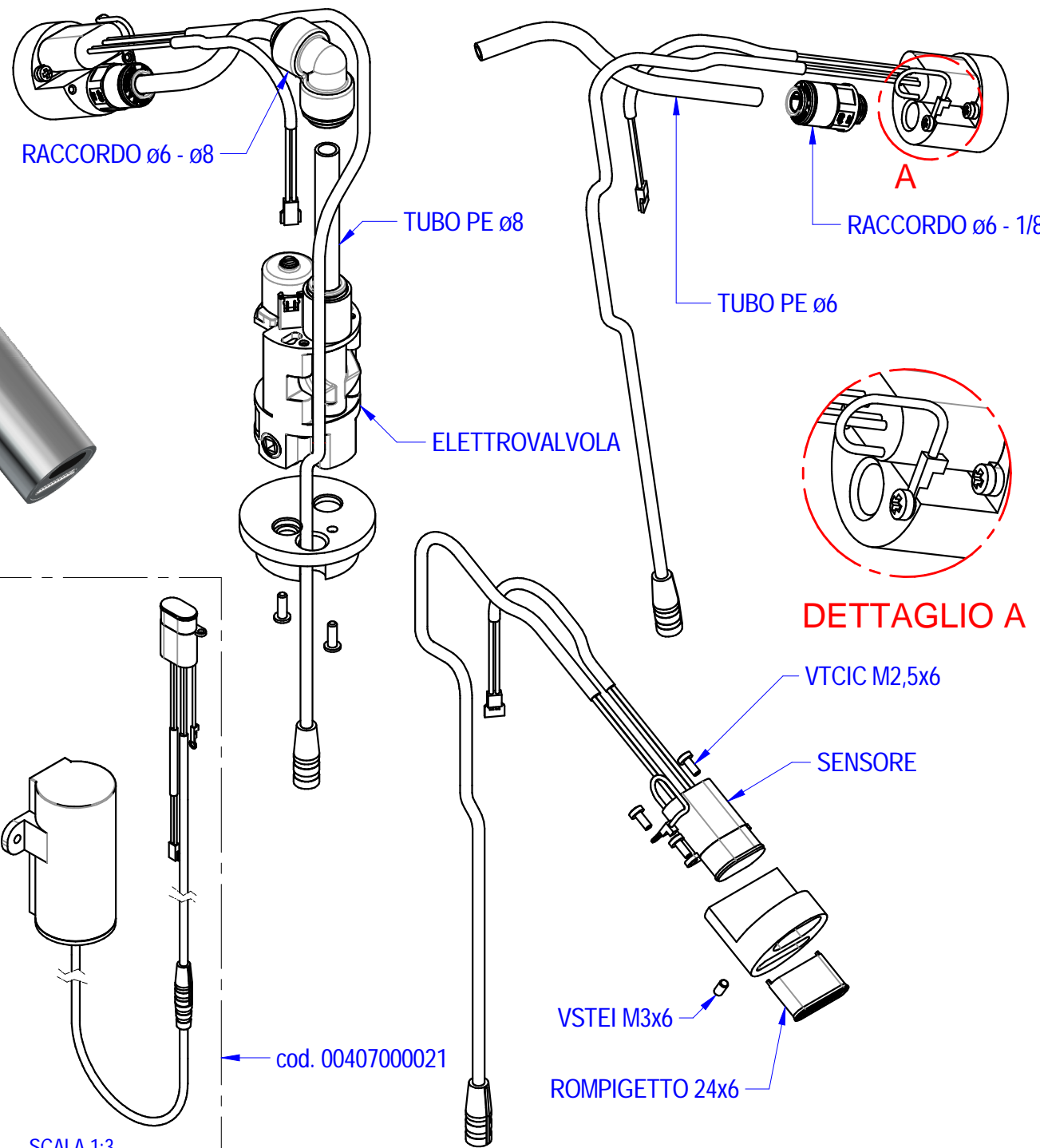

foro fissaggio a livello: ø33 mm

PORTATA : 6 L/min

Quote senza tolleranza secondo
 norma UNI-EN-22768-1-m

FORMATO
 A3



DATA
 30-11-2018

SCALA
 12

DENOMINAZIONE
**RUBINETTO ELETTRONICO LAVABO SERIE PREMIUM
 CON ALIMENTAZIONE A CORRENTE 100-240V**

CODICE
ZEUS001/C
 PESO
 1,59 Kg



Shop Group S.r.l.
 Via A. de Gasperi, 3
 01033 Civita Castellana (VT)
 info@shopgroup.it
 tel.0761-599396 w.a.3346878038