

NON IN DOTAZIONE
BATTERIE ALCALINE (4x1,5V AA)

00	---						
rev.		DESCRIZIONE MODIFICA					APPROVATO

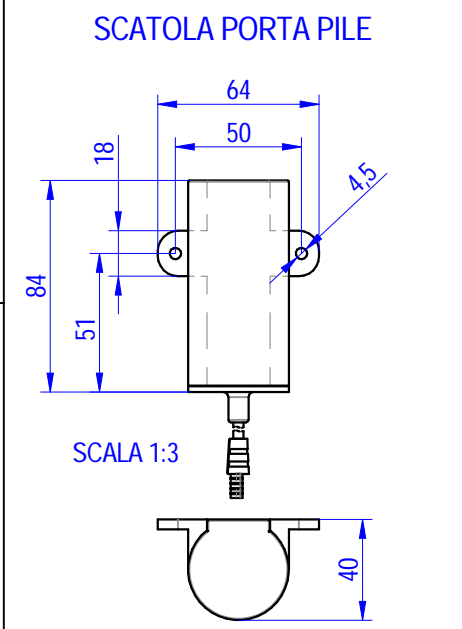
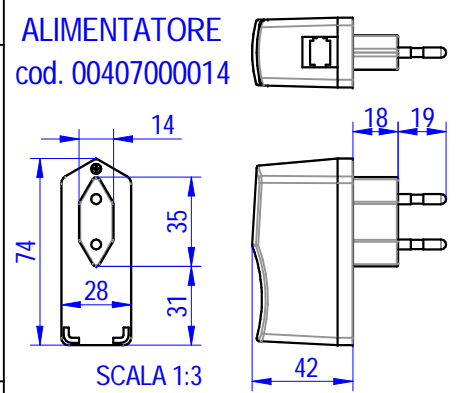

FLEX INOX (maschio corto)
 CON VALV. NON RITORNO (6 L/min)
 M10x1 - G1/2" L=400mm
 cod. 00403000108

FLEX INOX (maschio lungo)
 CON VALV. NON RITORNO (6 L/min)
 M10x1 - G1/2" L=400mm
 cod. 00403000109

TERMINAZIONE : Alimentatore switching con spina integrata, connettore RJ-9
ALIMENTAZIONE : 100-240V, 50-60Hz, 0.1 A

Quote senza tolleranza secondo norma **UNI-EN-22768-1-m**

FORMATO	
A3	Proiezione Europea
DATA	SCALA
30-11-2018	12

DENOMINAZIONE
MISCELATORE ELETTRONICO LAVABO
SERIE PREMIUM CON ALIMENTAZIONE A CORRENTE

CODICE
ZEUS002/C
 PESO
 1,63 Kg



Shop Group S.r.l.
 Via A. de Gasperi, 3
 01033 Civita Castellana (VT)
 info@shopgroup.it
 tel.0761-599396 w.a.3346878038